

HIGH PERFORMANCE BUTTERFLY VALVE DIMENSIONS

ANSI CLASS 600

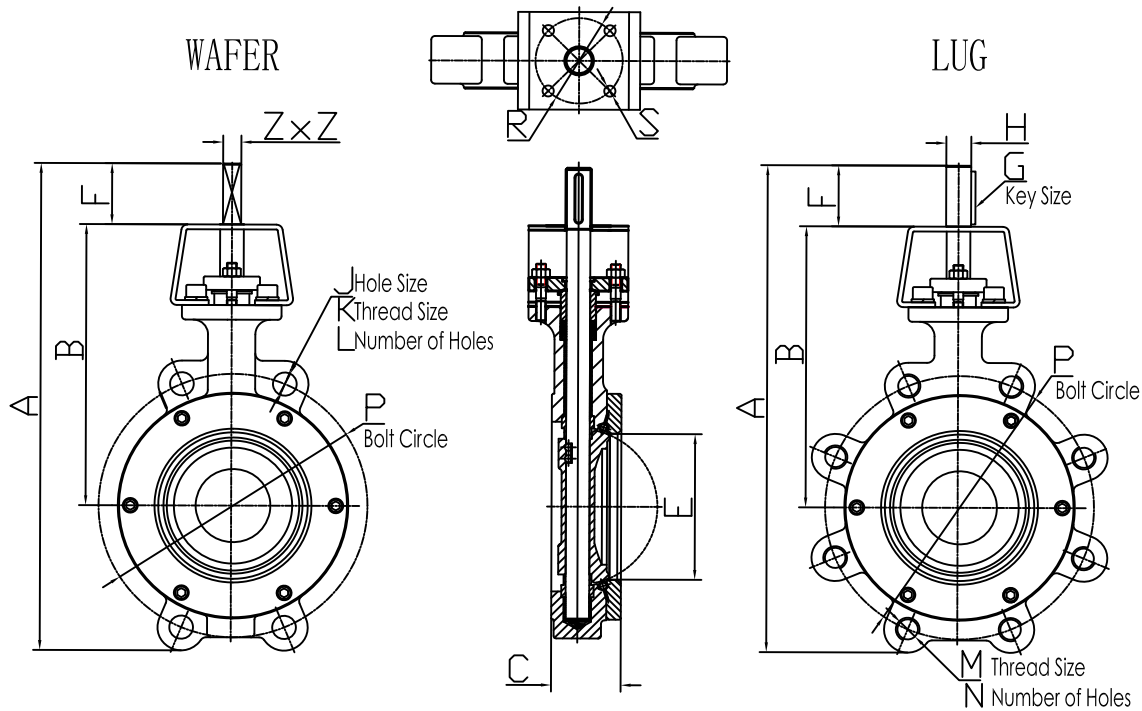

ANSI Class 600

VALVE SIZE	WAFER		LUG		B	C	E	F	ZxZ		J	K	L	M x N	P ins mm	R mm	S mm	WEIGHT (Kg)	
	mm	ins	A	A					ins/mm									G	H
50	2"	10.512 267	10.512 267	7.835 199	1.929 49	2.126 54	1.063 27	0.551*0.551 14*14	oval		4	5/8-11X8	5.00 127	ø70	4Xø9	7.5	8.5		
65	2½"	10.512 267	10.906 277	7.835 199	2.047 52	2.598 66	1.063 27	0.551*0.551 14*14					3/4-10X8	5.878 149.3	ø70	4Xø9	8.2	9.5	
80	3"	12.165 309	12.559 319	8.898 226	2.205 56	3.031 77	1.181 30	0.669*0.669 17*17					3/4-10X8	6.618 168.1	ø70	4Xø9	10.5	13	
100	4"	14.173 360	14.370 365	9.724 247	2.756 70	4.016 102	1.181 30	0.669*0.669 17*17					7/8-9X8	8.50 215.9	ø70	4Xø9	18.5	25	
150	6"	18.071 459	18.071 459	11.811 300	3.346 85	5.748 146	2.165 55	1.063*1.063 27*27		1-8	2	1-8X12	11.50 292.1	ø102	4Xø11	35	53		
200	8"	22.913 582	22.913 582	13.937 354	4.213 107	7.401 188	2.362 60	1.063*1.063 27*27		1½-8	4	1½-8X12	13.75 349.3	ø102	4Xø11	67	101		
250	10"	26.229 668	26.229 668	15.433 392	4.803 122	9.252 235	2.362 60	1.260*1.260 32*32		1¼-8	4	1¼-8X16	17.00 431.8	ø165	4Xø21	120	175		
300	12"	30.315 770	30.315 770	18.307 465	5.512 140	11.260 286	2.362 60	1.260*1.260 32*32		1¼-8	4	1¼-8X20	19.250 489.0	ø165	4Xø21	170	230		
350	14"	35.276 896	35.276 896	22.362 568	6.103 155	12.835 326	2.953 75	1.417*1.417 36*36		1½-8	4	1½-8X20	20.750 527.1	ø165	4Xø21	231	327		
400	16"	39.567 1005	39.567 1005	24.843 631	7.008 178	14.843 377	3.543 90	1.811*1.811 46*46		1½-8	4	1½-8X20	23.750 603.3	ø165	4Xø21	325	482		
450	18"	45.551 1157	45.551 1157	29.685 754	7.756 197	16.654 423	3.937 100	0.866 22	3.150 80	1½-8	4	1½-8X20	25.750 654.1	ø254	8Xø17	480	652		
500	20"	49.370 1254	49.370 1254	31.732 806	8.504 216	18.465 469	4.724 120	0.984 25	4.134 105	1½-8	4	1½-8X24	28.50 723.9	ø254	8Xø17	605	815		
600	24"	58.780 1493	58.780 1493	31.260 794	9.134 232	22.283 566	5.906 150	1.260 32	4.528 115	1½-8	4	1½-8X24	33.00 838.2	ø298	8Xø22	950	1285		

NOTE:

Drawings are for reference only. Please contact factory for separate drawing for each size at sales@huameimachinery.com. Huamei Machinery reserves the right to change product dimensions without notice.